

Additional Instruction Manual for R1CB Series Manual Chain Hoist & R1TS Series Trolley (R1CB,R1CBSG,R1CBSP,R1TSG,R1TSP)



Original Instruction

1. Application

These products are chain hoists designed to convey heavy materials, used inside architectural structures with the presence of atmosphere which contains Directive 94/9/EC designated explosive gasses and dust, and meets the Group II, Category 2 equipment requirements.

This instruction manual supplements the standard instruction manual if using a product for the purposes described above. Items not specifically described in this manual are according to the standard instruction manual.

In order to retain the heat of the hoist under the maximum during operation, the R1CB as well as R1TS series are based on the larger capacity of their standard chain hoist of M3 series or manual trolleys of TS series. The following list shows capacities between the R1CB, R1TS and standard products.

Rated Capacity	R1CB series	R1TS series
0.5t	M3 series CB010 Indicated capacity: 0.5t	TS series TSP010, TSG010 Indicated capacity: 0.5t
1t	M3 series CB015 Indicated capacity: 1.0t	TS series TSP020, TSG020 Indicated capacity: 1.0t
2t	M3 series CB030 Indicated capacity: 2.0t	TS series TSP030, TSG030 Indicated capacity: 2.0t
3t	M3 series CB050 Indicated capacity: 3.0t	TS series TSP050, TSG050 Indicated capacity: 3.0t

2. Legend to markings

E	x	II	2G	c	II B	T4
E	x	II	2D	c	1 3 5	°C

Ex : Acronym indicating the suitability of the manual hoist with or without trolley , to be used in explosion risk areas.

II : It indicates the equipment group. Group II is for non-mining equipment. It is intended for general factory applications.

2 : It classifies the product's category

Category 2 for applications in areas where during the average activities there are possibilities of creation of potentially dangerous gases (zone 1 or 21) and the hoist might provide a necessary safety level.

G : It indicates the possibility of using the hoist / trolley in the presence of potentially explosive elements such as gas steam or fog.

D : It indicates the possibility of using the hoist / trolley in the presence of potentially explosive elements such as dust.

II B : According to EN 13463-1 the main gases according to their sensibility to ignition had been subdivided. Hoists and trolleys marked II B are capable of being used also in the presence of elements belonging to IIA group.

T4 : It represents the temperature class for 2G group according to EN 13463-1 and indicates the highest possible surface temperature that the device can reach in normal functioning.

1 3 5 °C : It represents the temperature for 2D group and indicates the highest possible surface temperature that the device can reach in normal functioning.

3. Product Overview

The parts listed below for these products have been changed from the standard specifications to the specifications listed below, and are the non-sparking specifications if normally used in the environments described above.

- Bottom hook: Copper-plated
- Load chain: Nickel-diffused or nickel-plated chain
- Hand chain: SUS304
- Trolley track wheel: bronze, bronze-covered

Option

- Trolley track wheel: Copper-plated, stainless steel
- Trolley hand wheel: Iron casting for 2t and smaller
- Overload limiter

The bottom hook and trolley track wheel are copper-plated. Copper-plating is widely used for explosion-proofing of equipment, and is recognized as material that prevents the creation of sparks. Options for the trolley track wheel are copper-plated, bronze-covered, bronze or stainless steel, with such surface treatments and material qualities greatly reducing the possibility of spark creation. An option for 2-ton and less trolleys is the iron-casting hand wheel. (3-ton units have an iron-casting hand wheel as a standard part.) This greatly reduces the possibility of static electrification. The overload limiter is described in the standard instruction manual. Please refer to that manual.

4 . Safety Precautions

The following are precautions related to the characteristics of these products. All other items are according to the standard instruction manual.

(1) Main body

Do not use in the following manners as these can heighten the possibility of spark creation.

- (1) Do not allow the chain hoist to impact any other objects (do not swing or throw the chain hoist).
- (2) If used for an extended period of time, dust and other foreign material can get inside the main body, possibly resulting in the creation of sparks from friction of such foreign material and rotating parts. Periodically disassemble and inspect the parts.

(2) Bottom hook

The bottom hook is copper-plated in order to prevent the creation of sparks when contacting other metal parts. Check the copper-plating before operating, and do not use if the bare metal of the hook is exposed. Replace the hook if bare metal is exposed.

Experimental testing has proven that the bare metal of the hook will not be exposed when the hook is loaded at capacity for 20,000 repetitions.

Make sure that the hook cannot inadvertently contact any other objects. Impact with another object can result in a high possibility of sparks being created due to the material or surface form of the other object.

(3) Trolley track wheel

The trolley track wheel does not create sparks when used normally on a travelling rail.

However, do not pull the load chain with excessive force, making the trolley move at a speed exceeding the necessary speed, or subject to similar operation. Impact with another object can result in the high possibility of sparks being created due to the material or surface form of the other object.

Additionally, the presence of foreign material on the travelling rail can result in the high possibility of sparks being created. Periodically wipe off any foreign material.

Options for the trolley track wheel are copper-plated, bronze-covered, bronze or stainless steel. The table below shows the use limits. Periodically measure the dimensions and replace corresponding parts when any of the use limits have been exceeded.

WLL (t)	Larger tread diameter : D		Larger tread diameter : D'		Flange thickness :t	
	Standard	Limit	Standard	Limit	Standard	Limit
0.5	71	64	67	61	11	9.9
1	85	76	81	74	11	9.9
2	100	90	96	87	14	12.6
3	118	116.5	113	111.5	18	17

ϕD shows diameter for H-beam. $\phi D'$ shows diameter for I-beam.

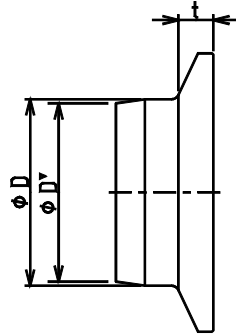

(4) Load chain

Regular inspect the load chain to make sure that no rust has formed. The formation of rust on the surface can result in the high possibility of sparks being created if the chain contacts another object.

(5) Hand chain

The hand chain is fabricated of stainless steel to greatly reduce the possibility of spark creation. Nonetheless, make sure that the hand chain does not contact any other objects. Impact with another object can result in a high possibility of sparks being created due to the material or surface form of the other object.

(6) Ground (Earth)

The upper hook and trolley track wheel of this unit can be grounded to the building as a means to prevent static electrification. There is a high possibility of spark creation if proper grounding with the building cannot be achieved due to a painted travelling rail or similar reason. Always be sure to securely ground the unit using a dedicated grounding cable.

Grounding of a suspended load is not possible if using a non-conductive suspension equipment such as a fiber sling. Be sure to use a grounding cable to directly ground the suspended load.

(7) Moving a suspended load

Sparks can be created if a suspended load contacts another object while being moved. Be careful that a suspended load does not contact another object while being moved

(1) The placement of the spacer of a trolley equal to or less than 2t is similar to a standard.

(2) The placement of the spacer of a trolley 3t is shown in table 1

As described below, track wheel for 3t is converted from standard track wheel and has deposited bronze on contact surface to beam rail.

Also, position of spacer is different from standard one due to flange thickness is different.

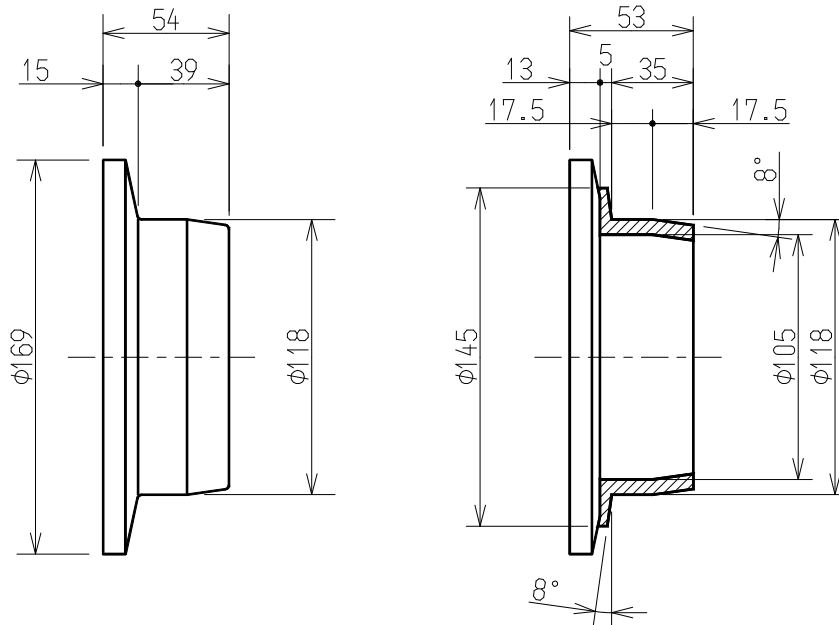

Standard

Bronze-covered

(3) The right and left side plates should be as far apart as possible, and the difference between A and B should be approximately 4mm. (According to the chart below)

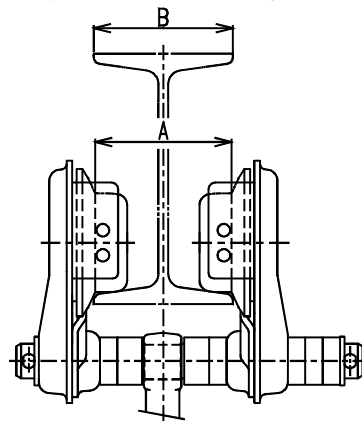
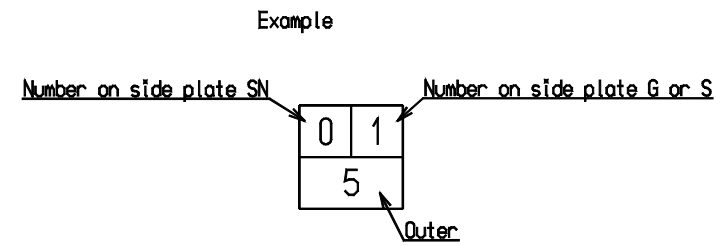
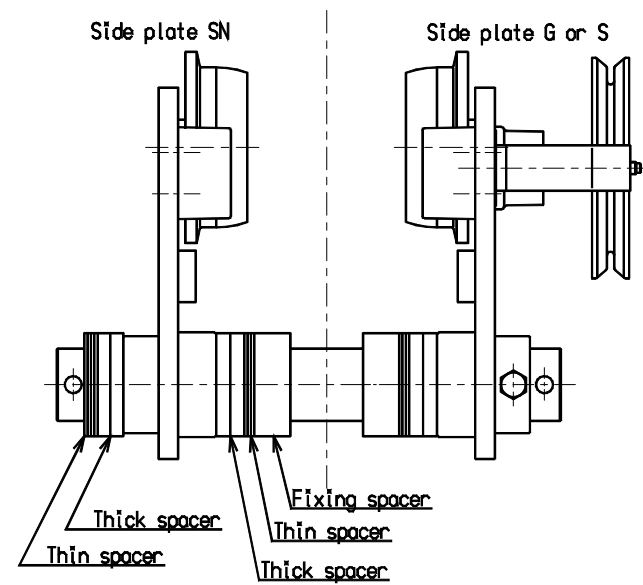

Table1

Capacity	Part Name	Number of spacers			Beam flange width (mm)																																																	
		Standard	W30		100	106	113	119	125	131	137	143	144	149	155	163	170	178	185	200	201	204	210	220	240	260	280	300	305																									
3t	Thin spacer	12	8	Inner	1	1	2	2	3	3	4	4	1	1	2	2	3	3	4	4	4	4	1	1	2	2	3	3	4	4	1	2	2	3	5	5	5	5	5	6	2	3	4	4	3	4	2	3	2	2	1	5	2	6
				Outer	10	8	6	4	10	8	6	4	4	4	10	8	6	4	4	9	7	2	2	1	3	0	1	3	4	2	0	0																						
	Thick spacer	6	9	Inner	0	0	0	0	0	0	1	1	1	1	1	1	1	1	1	2	2	2	2	2	2	2	2	2	2	3	3	3	3	3	3	3	3	3	3	3	1	1	1	1	2	2	3	3	4	4	5	4	5	4
				Outer	6	6	6	6	4	4	4	4	4	2	2	2	2	0	0	0	0	0	0	7	7	5	3	1	0	0																								
	Fixing spacer	0	2	Inner	0	0	0	0	0	0	0	0	0	0	0	0	0	0	0	0	0	0	0	0	0	0	0	0	0	0	0	0	0	0	0	0	0	0	0	0	0	0	0	0	0	0	0	0	0	0	0	0		
				Outer	0	0	0	0	0	0	0	0	0	0	0	0	0	0	0	0	0	0	0	0	0	0	0	0	0	0	0	0	0	0	0	0	0	0	0	0	0	0	0	0	0	0	0	0	0	0	0	0	0	0

Standard W30



KITO

URL:<http://www.kito.co.jp>